



WDD

Technical Guideline

2026

Laws and Regulations

- Decree No. (1) of the year 2004 pertaining to Water Connections Regulation.
- Decree No. (13) of the year 2006 regarding the regulation of charges for the delivery of electricity and water services.
- Decree No. (1) of the year 2007 regarding the fees of some Electricity and Water Services.
- Decree No. (7) of the year 2012 pertaining to Issuance of The Regulation Organizing Work in the Field of Plumbing.
- Decree No. (3) of the year 2015 regarding amendment of some provisions of The Organizing Work in the Field of Plumbing issued by Decree No. (7) of the year 2012.
- Decree No. (101) of the year 2022 regarding issuance of technical regulation for water-consumption conservation products.
- GCC Technical Regulation for Water-Consumption Conservation Products MC-230503-01.

Internal Plumbing

Internal Plumbing Requirements

It is required to comply with the relevant laws and regulations mentioned in the beginning of this document regarding internal water plumbing installations. These laws and regulations must be followed in all plumbing works within buildings and facilities. The following points outline the essential requirements, but are not limited to them:

1. Ground and roof water tanks must be provided. These tanks should be placed in accessible locations. It is recommended to allocate a permanent service room for roof tanks or to use sectional, thermally insulated tanks.
2. The water inlet to the ground tank must be no more than 1.5m above road level and within 30 meters from the location of the main water meter. This ensures continuous water flow even during low pressure periods. An isolation valve and a non-return valve must be installed on the supply pipe to the ground tank.

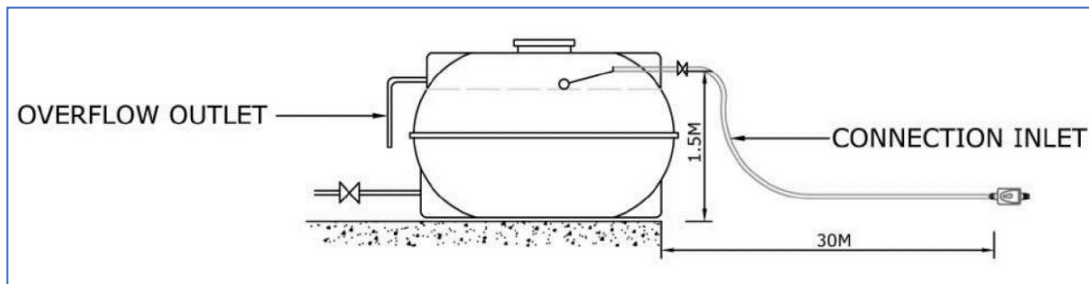

3. The overflow outlet of the ground and roof tank should be installed 3 to 5 cm below the water inlet.

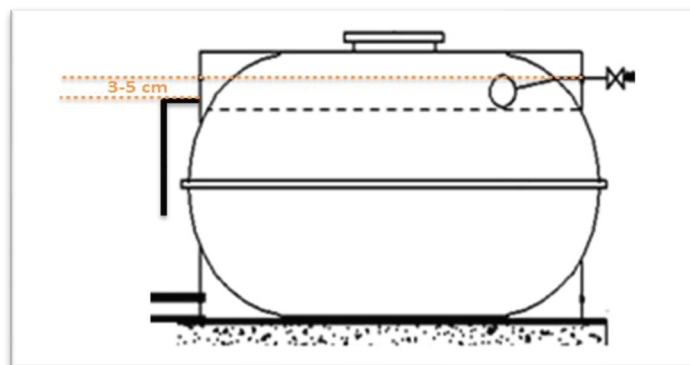

4. Overflow pipes from all water tanks must be visible and must not be connected to the sewage system.

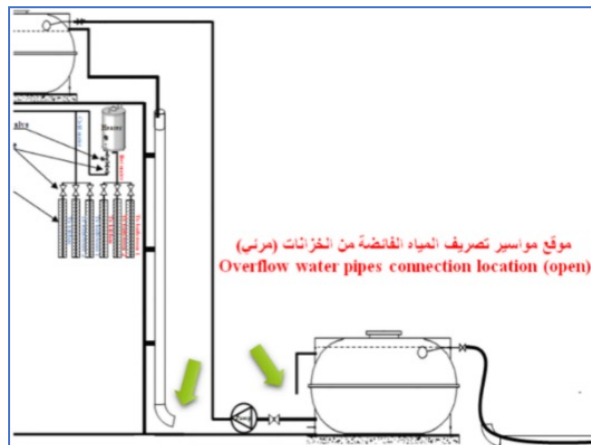

5. All internal network pipelines should be visible or passed through accessible pipe ducts to facilitate detection of leaks and easy replacement.

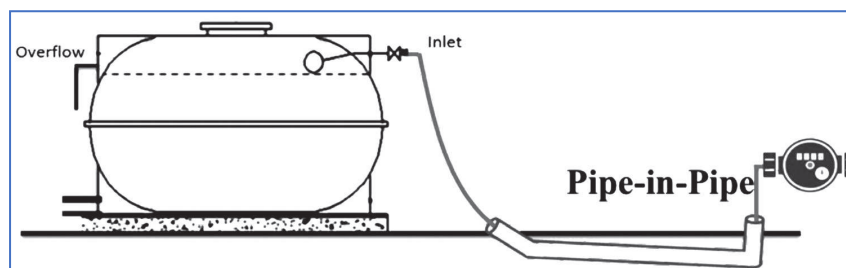

6. Isolation valves must be installed on the main water lines supplying each facility, as well as at the inlets and outlets of both ground and roof tanks, and at all service points within the internal network.

7. Water heaters must be equipped with a safety valve. Hot and cold water lines must be thermally insulated to prevent heat loss, and their lengths should be kept as short as possible.

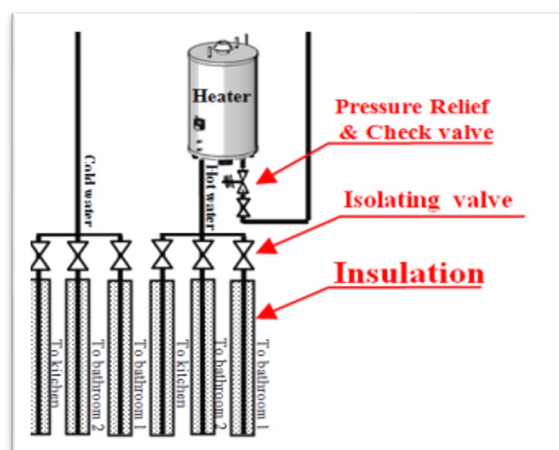

8. It is not permitted to connect any pump or device to the main supply pipe before the ground tank in order to increase pressure or modify internal water flow. It is also prohibited to install any tap on the main supply pipe before the ground tank.

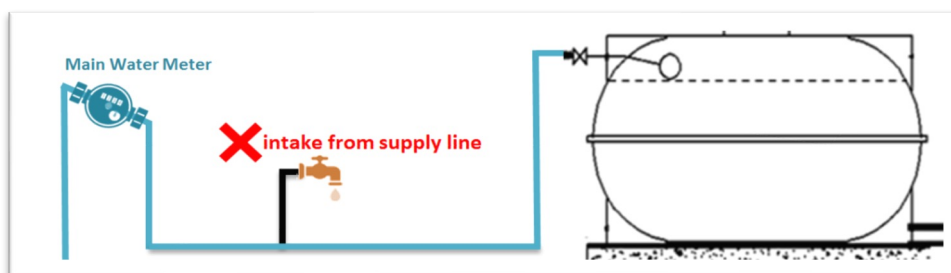
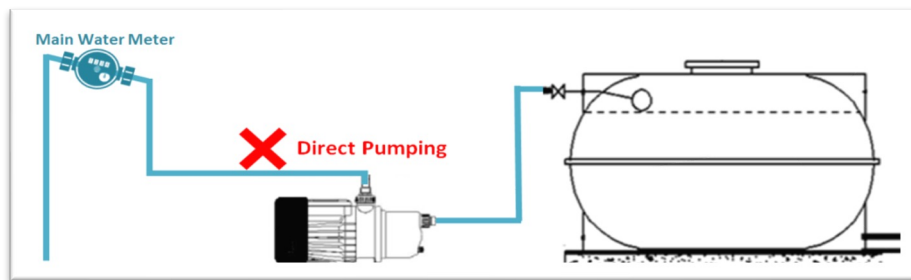

9. An audible or visual alarm system must be installed for underground water tanks or tanks with a capacity greater than 10 cubic meters to warn when water reaches the overflow level.

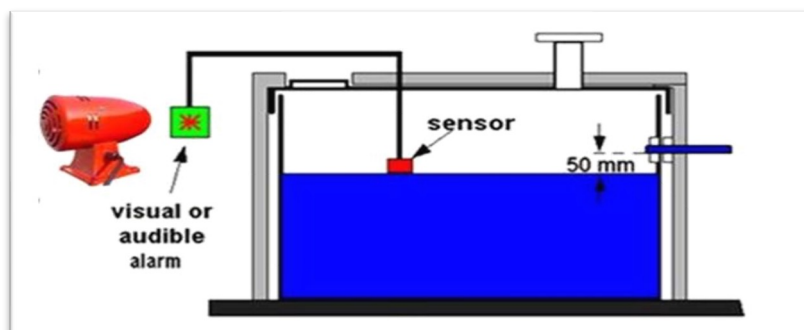

10. Toilet flush tanks (Siphon) must have a capacity not exceeding 6 liters and should be equipped with either a single or dual flush system. An isolation valve must be installed before the cistern.

| | |
|---------------------|--------------------------------|
| Dual Flush System | 4.0 Liters /6.0 Liters / Flush |
| Single Flush System | 4.8 Liters/ Flush |

11. The urinal flushing systems must be either manual (push-button) or electronic (sensor-based) and should operate only after use.

12. The licensed plumber shall conduct a hydraulic test of the internal network under a pressure of no less than 150% of the operational pressure of the network for a duration of 24 hours.

13. Suitable storage tanks must be provided, with capacity determined by the responsible engineering office based on the expected consumption. These tanks should be capable of meeting the demand for a minimum of (72) hours and must be appropriate for the size of the connecting pipe as per the table below:

| Connection Size (mm/inch) | Property Type | Required Storage Capacity (m ³) |
|---------------------------|---|---|
| 1/2 inch | All Units/ Flats | 1.5 m ³ / Flat |
| | All Villas / Houses | Villa /House Land Area ≤ 200 m ² Storage Capacity 4 m ³ |
| | | MOH and SOH Storage Capacity 5 m ³ |
| | Villa /House Land Area > 200 m ² Storage Capacity 6 m ³ | |
| 1 inch | All Units/ Flats | 1 m ³ / Flat |
| 2 inches | All Units/ Flats | 0.5 m ³ / Flat |
| Storage Distribution | Minimum capacity of 1 m ³ for ground water tank | |

- For non-residential property, Engineering Office is responsible for calculating the suitable storage capacity to meet the demand.

14. Isolating valves must be installed on all water lines supplying all the utilities of the premises.



15. The conservation water appliances must comply with the standards set by the Gulf Cooperation Council Standardization Organization (GSO).

16. The flow rate for sanitary fixtures must not exceed the following quantities:

| Products | Categories | Maximum Flow Rate (Liter/ min) | |
|--|--------------------------------------|--|-----|
| Water Taps, Mixers, Showerheads, WC hose-tap | Water Taps or Wash Basin Mixers/Taps | Water Taps or Wash Basin Mixers/Taps (Public) | 1.9 |
| | | Water Taps or Wash Basin Mixers/Taps (Private) | 5.7 |
| | | Sink Basin/bib taps or Kitchen taps/Mixers | 5.7 |
| | | Bidet Taps/Mixers | 5.7 |
| | | Ablution Taps/Mixers | 5.7 |
| | Taps/Showerheads | | 9.5 |
| | WC hose-tap or Shattaf Sprayer | | 5.7 |

17. The water supplied by the authority shall not be used for agricultural purposes. However, gardens and other ornamental plants are exempt from this restriction, provided that a separate tank is available for gardens with an area exceeding 50 square meters. The inlet to this tank must be at a higher level than the inlet of the main ground tank, with a height difference not exceeding 20 centimeters.

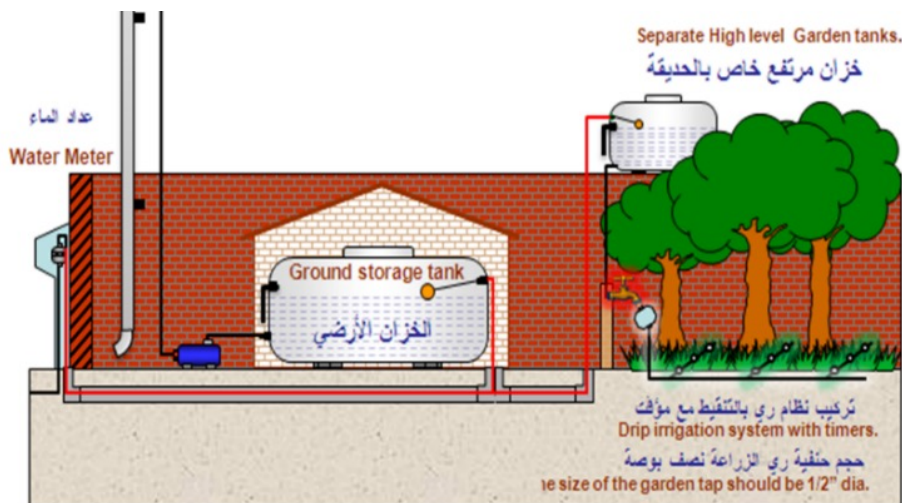

Water Meter Installation

Water Meter Installations

Reference to clause no (79) in the Decree No. (1) for the year 2004 pertaining to Water Connections Regulation, WDD has prepared a standards related to water meter installation, as illustrated herein.

There are different types of arrangements for Water Meter Installation according to the type of premises and the number of meters:

1 - Cavity for 15mm Connection:

- The standard size of water meter connection is (15mm).
- Cavity type to be installed on the permanent boundary wall.

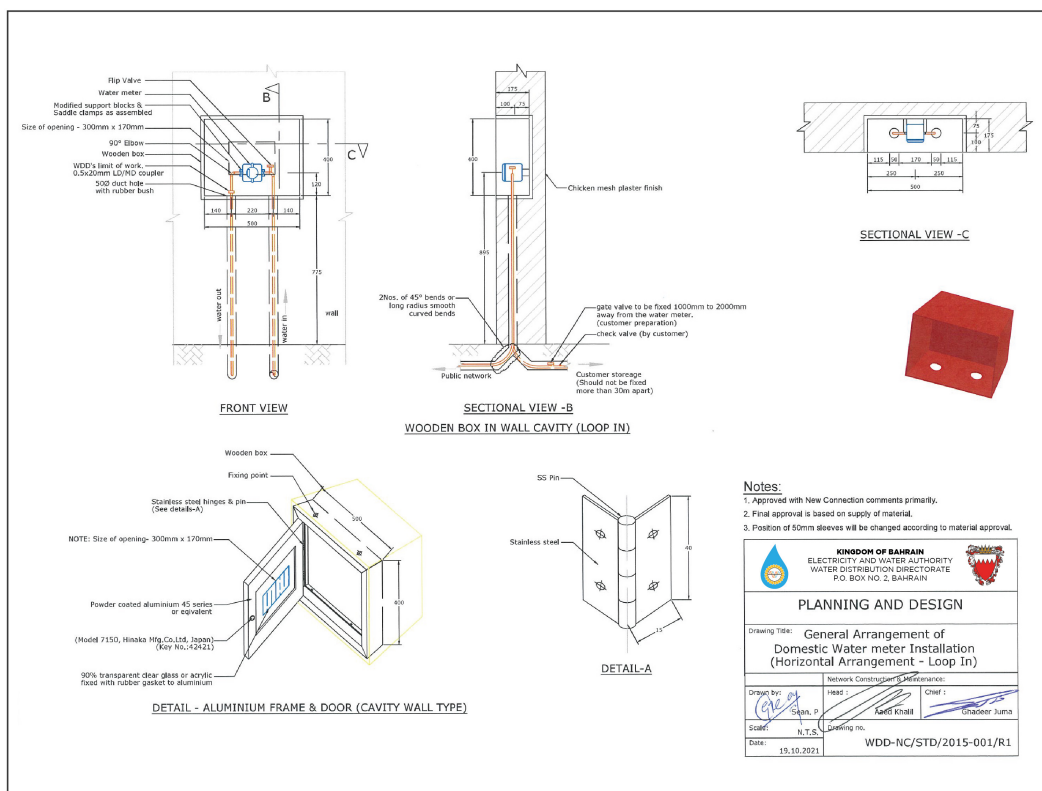

2 - Wall Mounted for 15 mm Connection:

- Wall mounted water meter type to be installed on the building wall where there is no boundary wall available.
- The meter to be installed on the side wall with a maximum distance of (1 m) from the property line if there is no wall on the front side of the property.

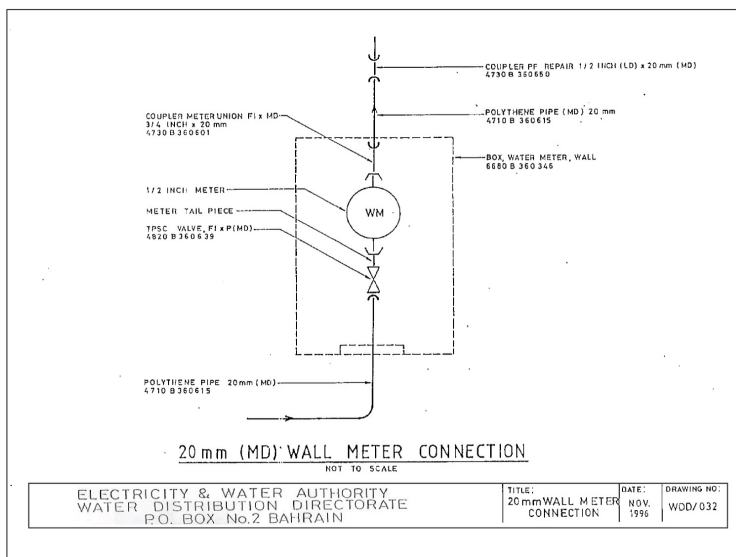
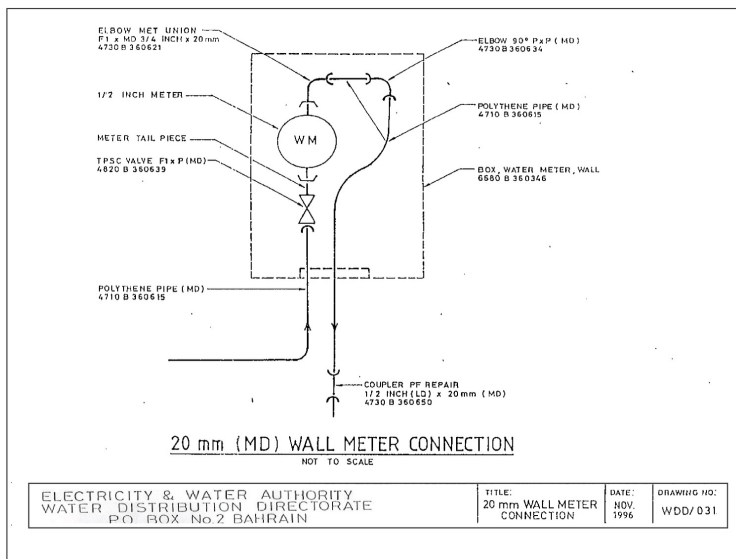

3 - Manifold System:

- Manifold is a system that consists of a group of meters which are supplied from one service line and each meter has its own storage tank.
- Manifold type to be installed on external boundary wall.
- The customer has to lay the internal pipes to the manifold box.
- Each unit must be provided with proper storage tanks independently.
- The maximum distance between the ground tank and the meter is not more than (30m).
- The size of manifold depends on the number of units, either (25mm) or (50mm).
- The table below shows number of meters that can be installed in manifold system and size of main pipe.

| Size of main pipe | No. of units can be supplied |
|-------------------|------------------------------|
| 25 mm | 5 units |
| 50 mm | 10 units |



6 - Sub-meters Installation:

- Sub-meter arrangements must be located in the roof or in each floor
- The customer is responsible to provide one gate valve for downstream and one check valve for upstream at each sub-meter.
- Each supply pipe must be clearly marked with the unit number of each (unit/flats/shops).
- In the event where the sub-meters will be installed in each floor, cabling system should be provided by the customer for the automatic meter reading.

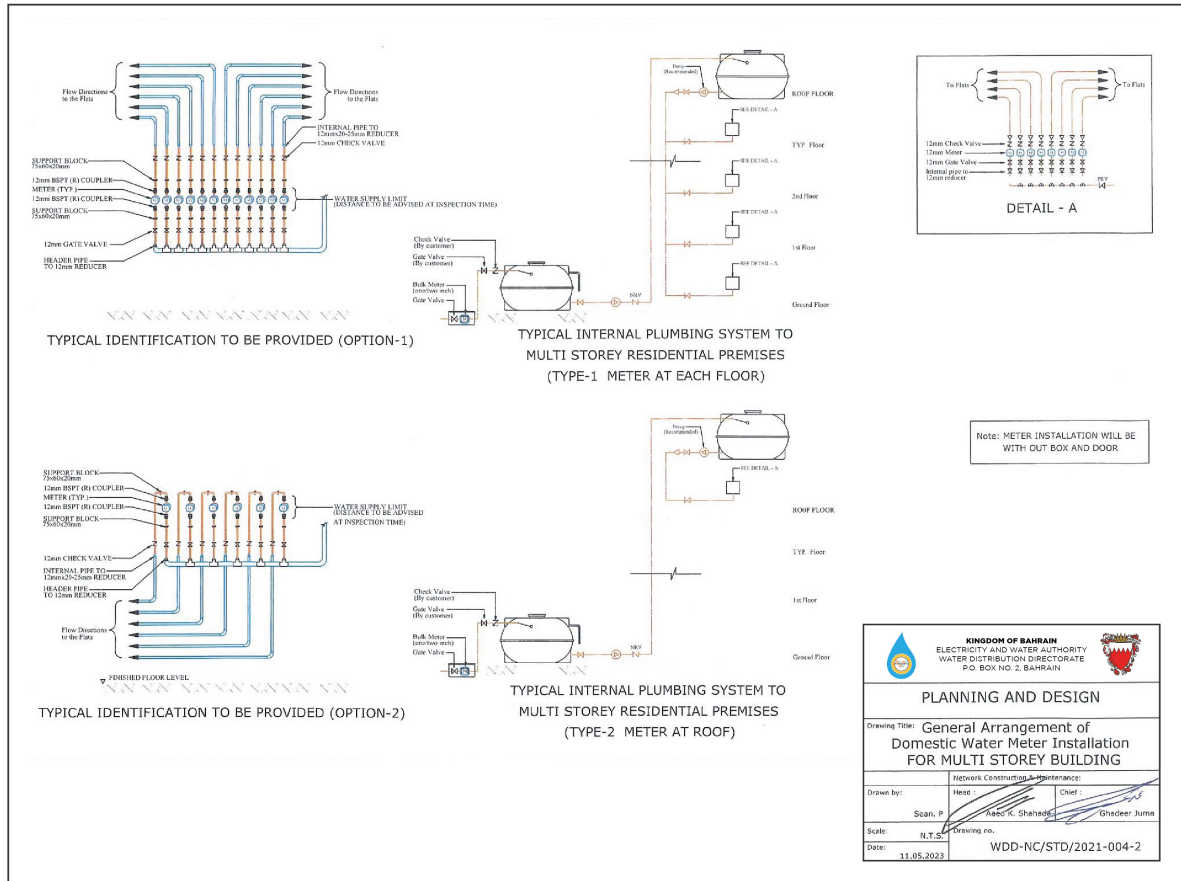

7 - Wiring System for Sub-meters Installation (if Applicable):

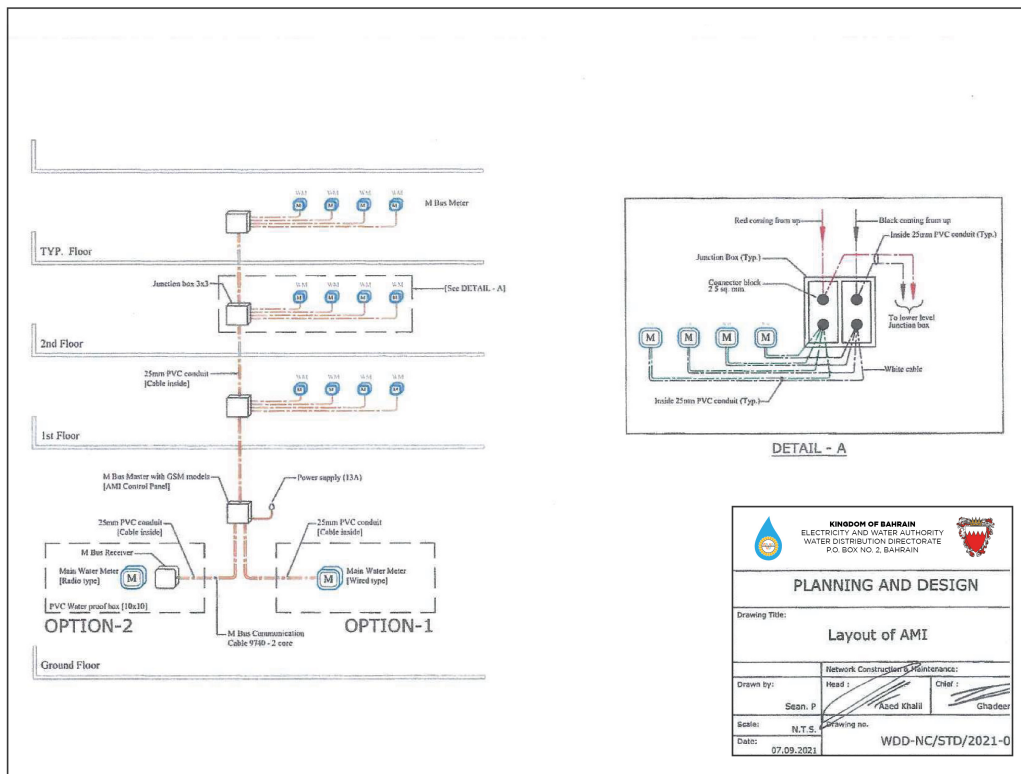

8 - Tanker Point

